

Mondo Matrix™ Cat5 Switcher



**Mondo Matrix™
2213001**

The Pro A/V Industry's Cat5 Switch Platform

RGBHV/audio/serial-ready, scalable
solution from 16x16 to 256x256 greatly
reduces rack space and connections

Magenta Research's pioneering Mondo Matrix™ is a full-matrix scalable Cat5 switch platform that distributes and switches video, audio and serial signals over a source to destination distance of one to fifteen hundred feet (457 meters), or more when using a Morph-It™ equipped with Dual EQ cards. The Mondo Matrix handles RGBHV, Component, HDTV, S-Video and Composite video at a maximum resolution of 2048x1536, with SPDIF digital audio, stereo or left/right mono audio, and/or simplex serial, depending on the accompanying MultiView transmitters and receivers.

Since the Mondo Matrix uses a single Cat5 in place of the five or more individual connectors needed in coax/BNC methods, the rack space required for a Mondo Matrix installation is typically 1/3 to 1/10 less. An array featuring the Mondo Matrix also significantly cuts power consumption, weight and installation labor. Furthermore, cabling costs can be reduced, as any category cables—shielded or unshielded—are compatible.

The Mondo Matrix is available in configurations that will meet the need of most design requirements, from 16x16 to 256x256, and is fully compatible with Magenta's full line of MultiView™ Series transmitters and receivers. The Mondo Matrix also features redundant (dual) power supplies for added reliability.

In order to achieve large configurations, Mondo Matrix frames (4U each) are cascaded vertically to satisfy large output ranges and horizontally to expand input needs. A 64x32 Mondo Matrix, for example, requires two frames (8U total).

Companion Products Include:



**Morph-It™ Powered Rack Frame
4003314**

Pairing the Morph-It with a Magenta MultiView Matrix, Mondo Matrix, or distribution amplifier grants the ability to zero out input distance, which allows operators to adjust skew and EQ for cable length a single time, rather than adjusting every time a new input and output are paired. Up to 500 feet of Cat5/UTP cable length can be electrically added or subtracted from the input source.



**MultiView UTx
Transmitter
4003212**



**MultiView PCI
Transmitter
4003246**



**MultiView AK500
Receiver
4003299**



**MultiView AK1000
Receiver
4003093**



**MultiView AK1500
Receiver
4003097**

Mondo Matrix™ Back Panel

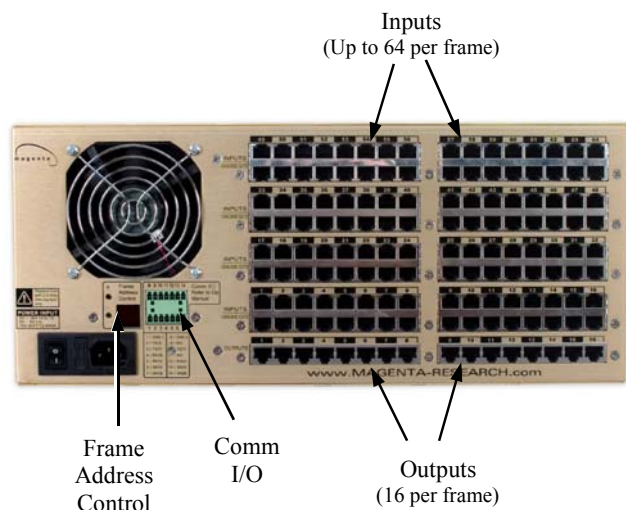



Features/Benefits of Use:

- Configurable from 16x16 to 256x256—in steps of 16 inputs or outputs—to meet a wide-range of larger-scale full-matrix switching applications
- Audio and/or serial pairs can be switched separately
- Used in conjunction with the MultiView Series of Cat5 transmitters and receivers, enabling high-resolution video, audio and serial distribution to 1500 feet (457 meters)
- Video, audio and/or serial signals are switched in combination, greatly reducing complexity
- Cat5 / RJ45 inputs and outputs, rather than BNC's, lead to a dramatic reduction in:
 - connections
 - rack space
 - power consumption
 - installation labor

Mondo Matrix™ Comparison

**64 in x 16 out
RGBHV with Audio**

THEN:	NOW:
Baseband Analog video switch with BNC connections	Cat5 switch with Magenta's Video over Cat5 technology
	
36 RU 6 Frames 1020 Watts 400 BNC Connects 80 Audio Connects 102 Pounds	4 RU 1 Frame 150 Watts Max 80 RJ45 Connects (for audio and video) 16 Pounds

One Mondo Matrix

Specifications:

Video & Aux Signals:

Signal configuration: 4 identical, individually routable channels per RJ-45 jack.
 Input impedance: 100Ω balanced (compatible with all MultiView equipment)
 Nominal input amplitude: 1 Volt P-P
 Dynamic headroom: >3dB
 Gain from transmitter input to receiver output through switch: Unity
 Coupling from transmitter input to receiver output: DC
 Circuitry bandwidth: >220MHz
 Signal type: 1,2,3,4 & 5 component video + aux channels (Via MultiView)
 Input connectors: Sixty-four (64) RJ-45 Female (Full Population)
 Loop out connectors: Sixty-four (64) RJ-45 Female (Full Population)
 Output connectors: Sixteen (16) RJ-45 Female
 Switch speed: 50 ns upon recognition of commands

Audio:

Audio signals are ported into the MondoMatrix via MultiView components. The type of transmitters and receivers used therefore defines audio specifications. Please refer to the spec sheets for those components.

Control:

Protocol to switch: RS-232/RS-422, Selectable; 9600 baud standard
 Protocol between master and slave frames: RS-232
 Interface connector, input: 7 position Phoenix
 Interface connector, output: 7 position Phoenix

All input to output switching commands are received and processed by the master frame. Additional frames used within the matrix are connected in a daisy chain and receive processed complex routing commands from the master frame.

Power:

Power input: 90~264 V / 50~60 Hz
 Consumption: 150 W Max

Environmental:

Temperature/humidity: Storage -40° to +158°F (-40° to +70°C) / 10% to 90% non-condensing
 Operating: 0° to +100°F (0° to +37°C) / 10% to 90%, non-condensing

Mechanical:

Rack mount: Standard, 4U 19" EIA
 Enclosure type: Front Panel: Powder coat chassis, passivated aluminum
 Enclosure dimensions: 6.7" H x 19" W x 10.5" D (170 mm H x 483 mm W x 267 mm D)
 Mass: 16 lbs (7.3 kg) fully populated
 Vibration: ISTA/NSTA 1A in carton (International Safe Transit Association)
 Compliances: CE; FCC Class A Safety: EN60950
 MTBF: 100,000 hours, nominal
 Warranty: 1 Year

Magenta Research is the undisputed leader in the adaptive distribution of audio/visual signals over Cat5 cable. Over eight years, Magenta has developed the highest-performance, most flexible video-over-Cat5 product line, the MultiView Series. The company utilizes patent-pending RepliSync™ and complex, state-variable signal EQ technologies to enable UXGA video distribution at 1,500 feet (457m) and QXGA video at 1,000 ft. (305m). MultiView Series transmitters, receivers, switchers and distributive systems have been installed in a large variety of A/V applications, especially dynamic signage for airport, retail, fast food, museum, casino, theatre, courtroom and corporate applications. Based in New Milford, CT, Magenta utilizes a network of international distributors, manufacturers representatives and resellers to market its enabling technology worldwide.

